

SPECIFICATION SHEET



PRODUCT CODE: PEX-229FA-C/P

DESCRIPTION:

1/2" x 1/2" angle valve with tricorn handle
(supplied with both hot and cold indices)

FINISH: Chrome

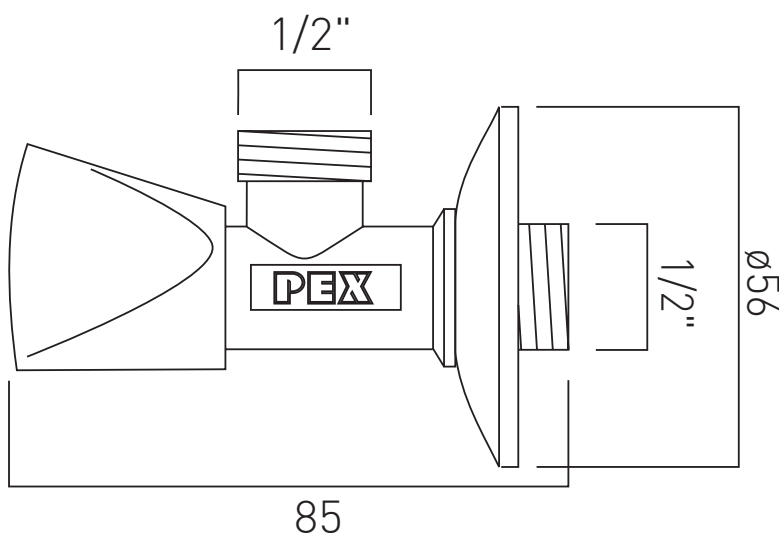

standard packing details	
item weight (kg)	0.182
inner box contains	1
box weight (kg)	0.204
outer carton contains	100
carton weight (kg)	20.5
full pallet contains	2400
pallet weight (kg)	507

tel: +44 (0)1934 745160
email: export@vado.com
www.vado.com

